

# DATA SHEET

## **80C652/83C652**

CMOS single-chip 8-bit microcontrollers

Product specification

1996 Aug 15

IC20 Data Handbook

# CMOS single-chip 8-bit microcontrollers

# 80C652/83C652

## DESCRIPTION

The P80C652/83C652 Single-Chip 8-Bit Microcontroller is manufactured in an advanced CMOS process and is a derivative of the 80C51 microcontroller family. The 80C652/83C652 has the same instruction set as the 80C51. Three versions of the derivative exist:

83C652 — 8k bytes mask programmable ROM

80C652 — ROMless version

87C652 — EPROM version (described in a separate chapter)

This device provides architectural enhancements that make it applicable in a variety of applications for general control systems. The 8XC652 contains a non-volatile 8k × 8 read-only program memory, a volatile 256 × 8 read/write data memory, four 8-bit I/O ports, two 16-bit timer/event counters (identical to the timers of the 80C51), a multi-source, two-priority-level, nested interrupt structure, an I<sup>2</sup>C interface, UART and on-chip oscillator and timing circuits. For systems that require extra capability, the 8XC652 can be expanded using standard TTL compatible memories and logic.

The device also functions as an arithmetic processor having facilities for both binary and BCD arithmetic plus bit-handling capabilities. The instruction set consists of over 100 instructions: 49 one-byte, 45 two-byte and 17 three-byte. With a 16(24)MHz crystal, 58% of the instructions are executed in 0.75(0.5)μs and 40% in 1.5(1)μs. Multiply and divide instructions require 3(2)μs.

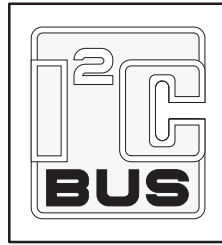

## FEATURES

- 80C51 central processing unit
- 8k × 8 ROM expandable externally to 64k bytes
- 256 × 8 RAM, expandable externally to 64k bytes
- Two standard 16-bit timer/counters
- Four 8-bit I/O ports
- I<sup>2</sup>C-bus serial I/O port with byte oriented master and slave functions
- Full-duplex UART facilities
- Power control modes
  - Idle mode
  - Power-down mode
- ROM code protection
- Extended frequency range: 1.2 to 24 MHz
  - 0 to +70°C
  - 40 to +85°C
  - 40 to +125°C
- Three operating ambient temperature ranges:

## PIN CONFIGURATIONS

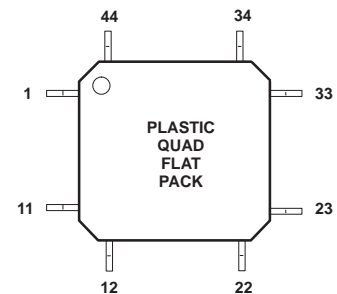
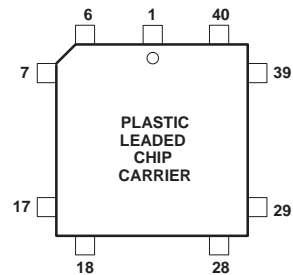
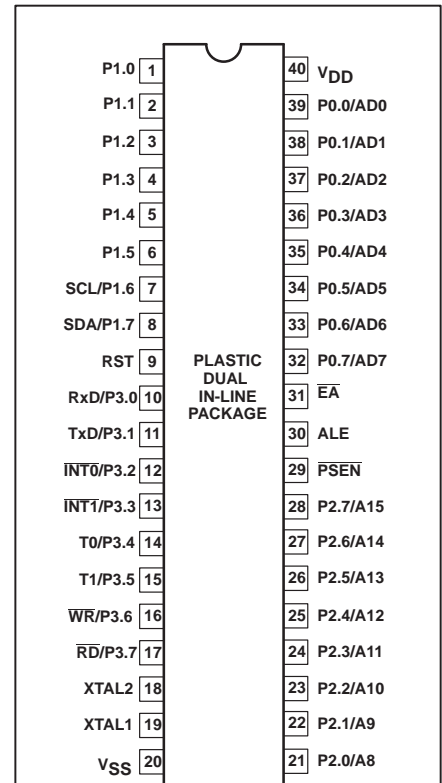

## LOGIC SYMBOL

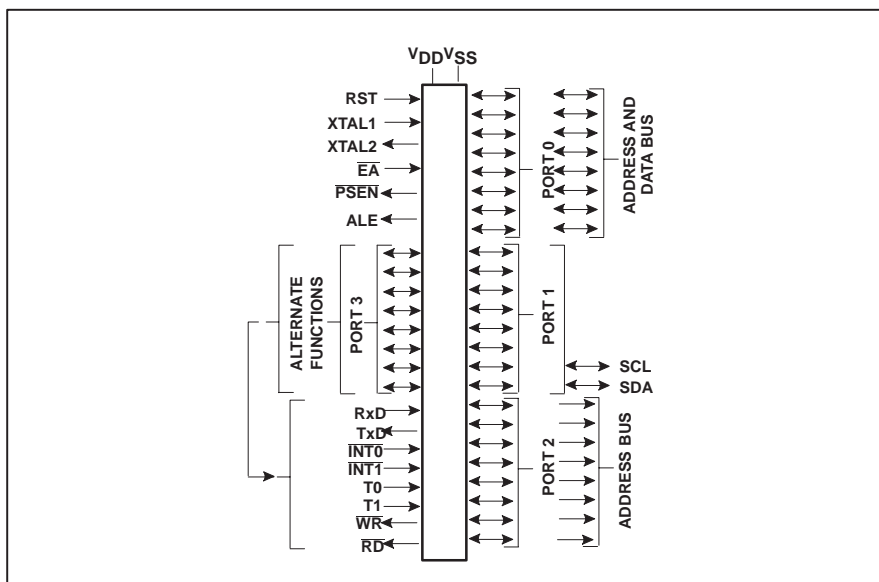

# CMOS single-chip 8-bit microcontrollers

# 80C652/83C652

## CERAMIC AND PLASTIC LEADED CHIP CARRIER PIN FUNCTIONS

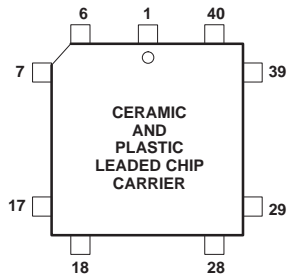

Pin	Function	Pin	Function
1	NC*	23	NC*
2	P1.0	24	P2.0/A8
3	P1.1	25	P2.1/A9
4	P1.2	26	P2.2/A10
5	P1.3	27	P2.3/A11
6	P1.4	28	P2.4/A12
7	P1.5	29	P2.5/A13
8	P1.6/SCL	30	P2.6/A14
9	P1.7/SDA	31	P2.7/A15
10	RST	32	PSEN
11	P3.0/RxD	33	ALE
12	NC*	34	NC*
13	P3.1/TxD	35	EA
14	P3.2/INT0	36	P0.7/AD7
15	P3.3/INT1	37	P0.6/AD6
16	P3.4/T0	38	P0.5/AD5
17	P3.5/T1	39	P0.4/AD4
18	P3.6/WR	40	P0.3/AD3
19	P3.7/RD	41	P0.2/AD2
20	XTAL2	42	P0.1/AD1
21	XTAL1	43	P0.0/AD0
22	VSS	44	VDD

\*DO NOT CONNECT

## PLASTIC QUAD FLAT PACK PIN FUNCTIONS

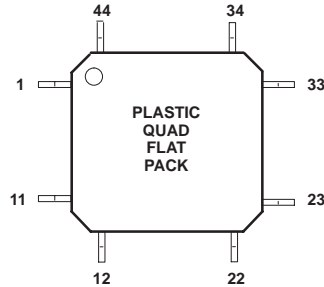

Pin	Function	Pin	Function
1	P1.5	23	P2.5/A13
2	P1.6/SCL	24	P2.6/A14
3	P1.7/SDA	25	P2.7/A15
4	RST	26	PSEN
5	P3.0/RxD	27	ALE
6	VSS4	28	VSS2
7	P3.1/TxD	29	EA/VPP
8	P3.2/INT0	30	P0.7/AD7
9	P3.3/INT1	31	P0.6/AD6
10	P3.4/T0	32	P0.5/AD5
11	P3.5/T1	33	P0.4/AD4
12	P3.6/WR	34	P0.3/AD3
13	P3.7/RD	35	P0.2/AD2
14	XTAL2	36	P0.1/AD1
15	XTAL1	37	P0.0/AD0
16	VSS1	38	VDD
17	NC*	39	VSS3
18	P2.0/A8	40	P1.0
19	P2.1/A9	41	P1.1
20	P2.2/A10	42	P1.2
21	P2.3/A11	43	P1.3
22	P2.4/A12	44	P1.4

\*DO NOT CONNECT

### NOTES TO QFP ONLY:

1. Due to EMC improvements, all VSS pins (6, 16, 28, 39) must be connected to VSS on the 80C652/83C652.

## CMOS single-chip 8-bit microcontrollers

80C652/83C652

## ORDER INFORMATION

PHILIPS PART ORDER NUMBER PART MARKING			PHILIPS NORTH AMERICA PART ORDER NUMBER		TEMPERATURE RANGE (°C)  AND PACKAGE	FREQ  MHz <sup>1,2</sup>
ROMless	ROM <sup>3</sup>	Drawing Number	ROMless	ROM		
P80C652FBP	P83C652FBP/xxx	SOT129-1	P80C652FBPN	P83C652FBPN	0 to +70, Plastic Dual In-line Package	16
P80C652FBA	P83C652FBA/xxx	SOT187-2	P80C652FBAA	P83C652FBAA	0 to +70, Plastic Leaded Chip Carrier	16
P80C652FBB	P83C652FBB/xxx	SOT307-2 <sup>4</sup>	P80C652FBBB	P83C652FBBB	0 to +70, Plastic Quad Flat Pack	16
P80C652FFP	P83C652FFP/xxx	SOT129-1	P80C652FFPN	P83C652FFPN	-40 to +85, Plastic Dual In-line Package	16
P80C652FFA	P83C652FFA/xxx	SOT187-2	P80C652FFAA	P83C652FFAA	-40 to +85, Plastic Leaded Chip Carrier	16
P80C652FFB	P83C652FFB/xxx	SOT307-2 <sup>4</sup>	P80C652FFBB	P83C652FFBB	-40 to +85, Plastic Quad Flat Pack	16
P80C652FHP	P83C652FHP/xxx	SOT129-1	P80C652FHPN	P83C652FHPN	-40 to +125, Plastic Dual In-line Package	16
P80C652FHA	P83C652FHA/xxx	SOT187-2	P80C652FHAA	P83C652FHAA	-40 to +125, Plastic Leaded Chip Carrier	16
P80C652FHB	P83C652FHB/xxx	SOT307-2 <sup>4</sup>	P80C652FHBB	P83C652FHBB	-40 to +125, Plastic Quad Flat Pack	16
P80C652IBP	P83C652IBP/xxx	SOT129-1	P80C652IBPN	P83C652IBPN	0 to +70, Plastic Dual In-line Package	24
P80C652IBA	P83C652IBA/xxx	SOT187-2	P80C652IBAA	P83C652IBAA	0 to +70, Plastic Leaded Chip Carrier	24
P80C652IBB	P83C652IBB/xxx	SOT307-2 <sup>4</sup>	P80C652IBBB	P83C652IBBB	0 to +70, Plastic Quad Flat Pack	24
P80C652IFP	P83C652IFP/xxx	SOT129-1	P80C652IFPN	P83C652IFPN	-40 to +85, Plastic Dual In-line Package	24
P80C652IFA	P83C652IFA/xxx	SOT187-2	P80C652IFAA	P83C652IFAA	-40 to +85, Plastic Leaded Chip Carrier	24
P80C652IFB	P83C652IFB/xxx	SOT307-2 <sup>4</sup>	P80C652IFBB	P83C652IFBB	-40 to +85, Plastic Quad Flat Pack	24

## NOTES:

1. 80C652 and 83C652 frequency range is 1.2MHz–16MHz or 1.2 to 24MHz.
2. For specification of the EPROM version, see the 87C652 data sheet.
3. xxx denotes the ROM code number.
4. SOT311 replaced by SOT307-2.

CMOS single-chip 8-bit microcontrollers

80C652/83C652

EPROM <sup>2</sup>	Drawing Number	TEMPERATURE RANGE (°C) AND PACKAGE	FREQ MHz <sup>1,2</sup>
S87C652-4N40	SOT129-1	0 to +70, Plastic Dual In-line Package	16
S87C652-4F40	0590B	0 to +70, Ceramic Dual In-line Package w/Window	16
S87C652-4A44	SOT187-2	0 to +70, Plastic Leaded Chip Carrier	16
S87C652-4K44	1472A	0 to +70, Ceramic Leaded Chip Carrier w/Window	16
S87C652-4B44	SOT307-2	0 to +70, Plastic Quad Flat Pack	16
S87C652-5N40	SOT129-1	-40 to +85, Plastic Dual In-line Package	16
S87C652-5F40	0590B	-40 to +85, Ceramic Dual In-line Package w/Window	16
S87C652-5A44	SOT187-2	-40 to +85, Plastic Leaded Chip Carrier	16
S87C652-5B44	SOT307-2	-40 to +85, Plastic Quad Flat Pack	16
S87C652-7N40	SOT129-1	0 to +70, Plastic Dual In-line Package	20
S87C652-7F40	0590B	0 to +70, Ceramic Dual In-line Package w/Window	20
S87C652-7A44	SOT187-2	0 to +70, Plastic Leaded Chip Carrier	20
S87C652-7K44	1472A	0 to +70, Ceramic Leaded Chip Carrier w/Window	20
S87C652-8N40	SOT129-1	-40 to +85, Plastic Dual In-line Package	20
S87C652-8F40	0590B	-40 to +85, Ceramic Dual In-line Package w/Window	20
S87C652-8A44	SOT187-2	-40 to +85, Plastic Leaded Chip Carrier	20

# CMOS single-chip 8-bit microcontrollers

# 80C652/83C652

## BLOCK DIAGRAM

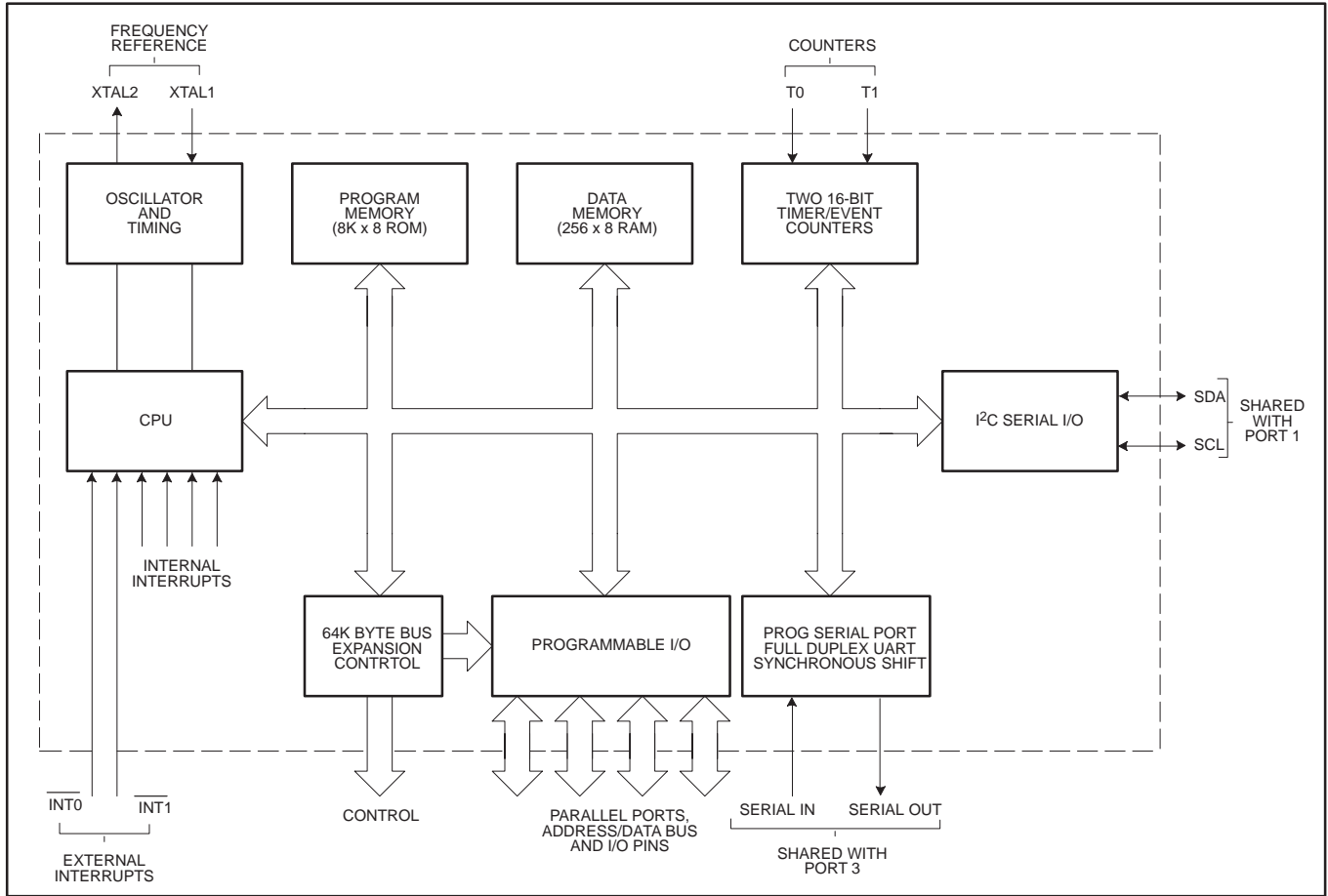

## CMOS single-chip 8-bit microcontrollers

80C652/83C652

## PIN DESCRIPTIONS

MNEMONIC	PIN NUMBER			TYPE	NAME AND FUNCTION
	DIP	PLCC	QFP		
V <sub>SS</sub>	20	22	6, 16, 28, 39	I	<b>Ground:</b> 0V reference. With the QFP package all V <sub>SS</sub> pins (V <sub>SS1</sub> to V <sub>SS4</sub> ) must be connected.
V <sub>DD</sub>	40	44	38	I	<b>Power Supply:</b> This is the power supply voltage for normal, idle, and power-down operation.
P0.0–P0.7	39–32	43–36	37–30	I/O	<b>Port 0:</b> Port 0 is an open-drain, bidirectional I/O port. Port 0 pins that have 1s written to them float and can be used as high-impedance inputs. Port 0 is also the multiplexed low-order address and data bus during accesses to external program and data memory. In this application, it uses strong internal pull-ups when emitting 1s.
P1.0–P1.7	1–8	2–9	40–44, 1–3	I/O	<b>Port 1:</b> Port 1 is an 8-bit bidirectional I/O port with internal pull-ups, except P1.6 and P1.7 which are open drain. Port 1 pins that have 1s written to them are pulled high by the internal pull-ups and can be used as inputs. As inputs, port 1 pins that are externally pulled low will source current because of the internal pull-ups. (See DC Electrical Characteristics: I <sub>IL</sub> ). Alternate functions include:
P1.6	7	8	2	I/O	<b>SCL:</b> I <sup>2</sup> C-bus serial port clock line.
P1.7	8	9	3	I/O	<b>SDA:</b> I <sup>2</sup> C-bus serial port data line.
P2.0–P2.7	21–28	24–31	18–25	I/O	<b>Port 2:</b> Port 2 is an 8-bit bidirectional I/O port with internal pull-ups. Port 2 pins that have 1s written to them are pulled high by the internal pull-ups and can be used as inputs. As inputs, port 2 pins that are externally being pulled low will source current because of the internal pull-ups. (See DC Electrical Characteristics: I <sub>IL</sub> ). Port 2 emits the high-order address byte during fetches from external program memory and during accesses to external data memory that use 16-bit addresses (MOVX @DPTR). In this application, it uses strong internal pull-ups when emitting 1s. During accesses to external data memory that use 8-bit addresses (MOV @Ri), port 2 emits the contents of the P2 special function register.
P3.0–P3.7	10–17	11, 13–19	5, 7–13	I/O	<b>Port 3:</b> Port 3 is an 8-bit bidirectional I/O port with internal pull-ups. Port 3 pins that have 1s written to them are pulled high by the internal pull-ups and can be used as inputs. As inputs, port 3 pins that are externally being pulled low will source current because of the pull-ups. (See DC Electrical Characteristics: I <sub>IL</sub> ). Port 3 also serves the special features of the 80C51 family, as listed below:
	10	11	5	I	<b>RxD (P3.0):</b> Serial input port
	11	13	7	O	<b>TxD (P3.1):</b> Serial output port
	12	14	8	I	<b>INT0 (P3.2):</b> External interrupt
	13	15	9	I	<b>INT1 (P3.3):</b> External interrupt
	14	16	10	I	<b>T0 (P3.4):</b> Timer 0 external input
	15	17	11	I	<b>T1 (P3.5):</b> Timer 1 external input
	16	18	12	O	<b>WR (P3.6):</b> External data memory write strobe
	17	19	13	O	<b>RD (P3.7):</b> External data memory read strobe
RST	9	10	4	I	<b>Reset:</b> A high on this pin for two machine cycles while the oscillator is running, resets the device. An internal diffused resistor to V <sub>SS</sub> permits a power-on reset using only an external capacitor to V <sub>DD</sub> .
ALE	30	33	27	I/O	<b>Address Latch Enable:</b> Output pulse for latching the low byte of the address during an access to external memory. In normal operation, ALE is emitted at a constant rate of 1/6 the oscillator frequency. Note that one ALE pulse is skipped during each access to external data memory.
PSEN	29	32	26	O	<b>Program Store Enable:</b> Read strobe to external program memory via Port 0 and Port 2. It is activated twice each machine cycle during fetches from the external program memory. When executing out of external program memory two activations of PSEN are skipped during each access to external data memory. PSEN is not activated (remains HIGH) during no fetches from external program memory. PSEN can sink/source 8 LSTTL inputs and can drive CMOS inputs without external pull-ups.
E <sub>A</sub>	31	35	29	I	<b>External Access:</b> If during a RESET, E <sub>A</sub> is held at TTL, level HIGH, the CPU executes out of the internal program memory ROM provided the Program Counter is less than 8192. If during a RESET, E <sub>A</sub> is held a TTL LOW level, the CPU executes out of external program memory. E <sub>A</sub> is not allowed to float.
XTAL1	19	21	15	I	<b>Crystal 1:</b> Input to the inverting oscillator amplifier and input to the internal clock generator circuits.
XTAL2	18	20	14	O	<b>Crystal 2:</b> Output from the inverting oscillator amplifier.

**NOTE:**

To avoid "latch-up" effect at power-on, the voltage on any pin at any time must not be higher than V<sub>DD</sub> + 0.5V or V<sub>SS</sub> - 0.5V, respectively.

CMOS single-chip 8-bit microcontrollers

80C652/83C652

Table 1. 8XC652/654 Special Function Registers

SYMBOL	DESCRIPTION	DIRECT ADDRESS	BIT ADDRESS, SYMBOL, OR ALTERNATIVE PORT FUNCTION								RESET VALUE
			MSB				LSB				
ACC*	Accumulator	E0H	E7	E6	E5	E4	E3	E2	E1	E0	00H
B*	B register	F0H	F7	F6	F5	F4	F3	F2	F1	F0	00H
DPTR:	Data pointer (2 bytes)										
DPH	Data pointer high	83H									00H
DPL	Data pointer low	82H									00H
			AF	AE	AD	AC	AB	AA	A9	A8	
IE*#	Interrupt enable	A8H	EA		ES1	ES0	ET1	EX1	ET0	EX0	0x000000B
			BF	BE	BD	BC	BB	BA	B9	B8	
IP*#	Interrupt priority	B8H	—		PS1	PS0	PT1	PX1	PT0	PX0	xx000000B
			87	86	85	84	83	82	81	80	
P0*	Port 0	80H	AD7	AD6	AD5	AD4	AD3	AD2	AD1	AD0	FFH
			97	96	95	94	93	92	91	90	
P1*#	Port 1	90H	SDA	SCL							FFH
			A7	A6	A5	A4	A3	A2	A1	A0	
P2*	Port 2	A0H	A15	A14	A13	A12	A11	A10	A9	A8	FFH
			B7	B6	B5	B4	B3	B2	B1	B0	
P3*	Port 3	B0H	R $\bar{D}$	WR	T1	T0	INT1	INT $\bar{0}$	TXD	RXD	FFH
PCON	Power control	87H	SMOD	—	—	—	GF1	GF0	PD	IDL	0xxx0000B
			9F	9E	9D	9C	9B	9A	99	98	
S0CON*#	Serial 0 port control	98H	SM0	SM1	SM2	REN	TB8	RB8	TI	RI	00H
S0BUF#	Serial 0 data buffer	99H									xxxxxxxB
			D7	D6	D5	D4	D3	D2	D1	D0	
PSW*	Program status word	D0H	CY	AC	F0	RS1	RS0	OV	F1	P	00H
S1DAT#	Serial 1 data	DAH									00H
SP	Stack pointer	81H									07H
S1ADR#	Serial 1 address	DBH	SLAVE ADDRESS							GC	00H
S1STA#	Serial 1 status	D9H	SC4	SC3	SC2	SC1	SC0	0	0	0	F8H
			DF	DE	DD	DC	DB	DA	D9	D8	
S1CON*#	Serial 1 control	D8H	CR2	ENS1	STA	STO	SI	AA	CR1	CR0	00000000B
			8F	8E	8D	8C	8B	8A	89	88	
TCON*	Timer control	88H	TF1	TR1	TF0	TR0	IE1	IT1	IE0	IT0	00H
TH1	Timer high 1	8DH									00H
TH0	Timer high 0	8CH									00H
TL1	Timer low 1	8BH									00H
TL0	Timer low 0	8AH									00H
TMOD	Timer mode	89H	GATE	C $\bar{T}$	M1	M0	GATE	C $\bar{T}$	M1	M0	00H

\* SFRs are bit addressable.

# SFRs are modified from or added to the 80C51 SFRs.



# CMOS single-chip 8-bit microcontrollers

# 80C652/83C652

## ROM CODE PROTECTION (83C652)

The 8XC652 has an additional security feature. ROM code protection may be selected by setting a mask-programmable security bit (i.e., user dependent). This feature may be requested during ROM code submission. When selected, the ROM code is protected and cannot be read out at any time by any test mode or by any instruction in the external program memory space.

The MOVC instructions are the only instructions that have access to program code in the internal or external program memory. The  $\overline{EA}$  input is latched during RESET and is "don't care" after RESET (also if the security bit is not set). This implementation prevents reading internal program code by switching from external program memory to internal program memory during a MOVC instruction or any other instruction that uses immediate data.

## OSCILLATOR CHARACTERISTICS

XTAL1 and XTAL2 are the input and output, respectively, of an inverting amplifier. The pins can be configured for use as an on-chip oscillator, as shown in the Logic Symbol, page 2.

To drive the device from an external clock source, XTAL1 should be driven while XTAL2 is left unconnected. There are no requirements on the duty cycle of the external clock signal, because the input to the internal clock circuitry is through a divide-by-two flip-flop. However, minimum and maximum high and low times specified in the data sheet must be observed.

### Reset

A reset is accomplished by holding the RST pin high for at least two machine cycles (24 oscillator periods), while the oscillator is running. To insure a good power-on reset, the RST pin must be high long enough to allow the oscillator time to start up (normally a few milliseconds) plus two machine cycles. At power-on, the voltage on  $V_{DD}$  and RST must come up at the same time for a proper start-up.

### Idle Mode

In the idle mode, the CPU puts itself to sleep while all of the on-chip peripherals stay active. The instruction to invoke the idle mode is the last instruction executed in the normal operating mode before the idle mode is activated. The CPU contents, the on-chip RAM, and all of the special function registers remain intact during this mode. The idle mode can be terminated either by any

enabled interrupt (at which time the process is picked up at the interrupt service routine and continued), or by a hardware reset which starts the processor in the same manner as a power-on reset.

### Power-Down Mode

In the power-down mode, the oscillator is stopped and the instruction to invoke power-down is the last instruction executed. Only the contents of the on-chip RAM are preserved. A hardware reset is the only way to terminate the power-down mode. The control bits for the reduced power modes are in the special function register PCON. Table 2 shows the state of the I/O ports during low current operating modes.

### I<sup>2</sup>C Serial Communication—SIO1

The I<sup>2</sup>C serial port is identical to the I<sup>2</sup>C serial port on the 8XC552. The operation of this subsystem is described in detail in the 8XC552 section of this manual.

Note that in both the 8XC652/4 and the 8XC552 the I<sup>2</sup>C pins are alternate functions to port pins P1.6 and P1.7. Because of this, P1.6 and P1.7 on these parts do not have a pull-up structure as found on the 80C51. Therefore P1.6 and P1.7 have open drain outputs on the 8XC652/4.

**Table 2. External Pin Status During Idle and Power-Down Mode**

MODE	PROGRAM MEMORY	ALE	$\overline{PSEN}$	PORT 0	PORT 1	PORT 2	PORT 3
Idle	Internal	1	1	Data	Data	Data	Data
Idle	External	1	1	Float	Data	Address	Data
Power-down	Internal	0	0	Data	Data	Data	Data
Power-down	External	0	0	Float	Data	Data	Data

### Serial Control Register (S1CON) – See Table 3

S1CON (D8H)	CR2	ENS1	STA	STO	SI	AA	CR1	CR0
-------------	-----	------	-----	-----	----	----	-----	-----

Bits CR0, CR1 and CR2 determine the serial clock frequency that is generated in the master mode of operation.

**Table 3. Serial Clock Rates**

CR2	CR1	CR0	BIT FREQUENCY (kHz) AT $f_{osc}$				$f_{osc}$ DIVIDED BY
			6MHz	12MHz	16MHz	24MHz	
0	0	0	23	47	62.5	94	256
0	0	1	27	54	71	107 <sup>1</sup>	224
0	1	0	31.25	62.5	83.3	125 <sup>1</sup>	192
0	1	1	37	75	100	150 <sup>1</sup>	160
1	0	0	6.25	12.5	17	25	960
1	0	1	50	100	133 <sup>1</sup>	200 <sup>1</sup>	120
1	1	0	100	200 <sup>1</sup>	267 <sup>1</sup>	400 <sup>1</sup>	60
1	1	1	0.24 < 62.5 0 to 255	0.49 < 62.5 0 to 254	0.65 < 55.6 0 to 253	0.98 < 50.0 0 to 251	96 × (256 – (reload value Timer 1)) reload value range Timer 1 (in mode 2)

**NOTES:**

1. These frequencies exceed the upper limit of 100kHz of the I<sup>2</sup>C-bus specification and cannot be used in an I<sup>2</sup>C-bus application.

## CMOS single-chip 8-bit microcontrollers

80C652/83C652

**ABSOLUTE MAXIMUM RATINGS<sup>1, 2, 3</sup>**

PARAMETER	RATING	UNIT
Storage temperature range	-65 to +150	°C
Voltage on any other pin to $V_{SS}$	-0.5 to + 6.5	V
Input, output current on any single pin	±5	mA
Power dissipation (based on package heat transfer limitations, not device power consumption)	1	W

**NOTES:**

- Stresses above those listed under Absolute Maximum Ratings may cause permanent damage to the device. This is a stress rating only and functional operation of the device at these or any conditions other than those described in the AC and DC Electrical Characteristics section of this specification is not implied.
- This product includes circuitry specifically designed for the protection of its internal devices from the damaging effects of excessive static charge. Nonetheless, it is suggested that conventional precautions be taken to avoid applying greater than the rated maxima.
- Parameters are valid over operating temperature range unless otherwise specified. All voltages are with respect to  $V_{SS}$  unless otherwise noted.

**DEVICE SPECIFICATIONS**

TYPE	SUPPLY VOLTAGE (V)		FREQUENCY (MHz)		TEMPERATURE RANGE (°C)
	MIN.	MAX.	MIN.	MAX.	
P8XC652FBx	4.0	6.0	1.2	16	0 to +70
P8XC652FFx	4.0	6.0	1.2	16	-40 to +85
P8XC652FHx	4.5	5.5	1.2	16	-40 to +125
P8XC652IBx	4.5	5.5	1.2	24	0 to +70
P83X652IFx	4.5	5.5	1.2	24	-40 to +85

## CMOS single-chip 8-bit microcontrollers

## 80C652/83C652

## DC ELECTRICAL CHARACTERISTICS

 $V_{SS} = 0V$ 

SYMBOL	PARAMETER	PART TYPE	TEST CONDITIONS	LIMITS		UNIT
				MIN.	MAX.	
$V_{IL}$	Input low voltage, except $\overline{EA}$ , P1.6/SCL, P1.7/SDA	0 to +70°C		-0.5	$0.2V_{DD}-0.1$	V
		-40 to +85°C		-0.5	$0.2V_{DD}-0.15$	V
		-40 to +125°C		-0.5	$0.2V_{DD}-0.25$	V
$V_{IL1}$	Input low voltage to $\overline{EA}$	0 to +70°C		-0.5	$0.2V_{DD}-0.3$	V
		-40 to +85°C		-0.5	$0.2V_{DD}-0.35$	V
		-40 to +125°C		-0.5	$0.2V_{DD}-0.45$	V
$V_{IL2}$	Input low voltage to P1.6/SCL, P1.7/SDA <sup>6</sup>			-0.5	$0.3V_{DD}$	V
$V_{IH}$	Input high voltage, except XTAL1, RST, P1.6/SCL, P1.7/SDA	0 to +70°C		$0.2V_{DD}+0.9$	$V_{DD}+0.5$	V
		-40 to +85°C		$0.2V_{DD}+1.0$	$V_{DD}+0.5$	V
		-40 to +125°C		$0.2V_{DD}+1.0$	$V_{DD}+0.5$	V
$V_{IH1}$	Input high voltage, XTAL1, RST	0 to +70°C		$0.7V_{DD}$	$V_{DD}+0.5$	V
		-40 to +85°C		$0.7V_{DD}+0.1$	$V_{DD}+0.5$	V
		-40 to +125°C		$0.7V_{DD}+0.1$	$V_{DD}+0.5$	V
$V_{IH2}$	Input high voltage, P1.6/SCL, P1.7/SDA <sup>6</sup>			$0.7V_{DD}$	6.0	V
$V_{OL}$	Output low voltage, ports 1, 2, 3, except P1.6/SCL, P1.7/SDA		$I_{OL} = 1.6mA^{8,9}$		0.45	V
$V_{OL1}$	Output low voltage, port 0, ALE, PSEN		$I_{OL} = 3.2mA^{8,9}$		0.45	V
$V_{OL2}$	Output low voltage, P1.6/SCL, P1.7/SDA		$I_{OL} = 3.0mA$		0.4	V
$V_{OH}$	Output high voltage, ports 1, 2, 3, ALE, $\overline{PSEN}^{10}$		$I_{OH} = -60\mu A$	2.4		V
			$I_{OH} = -25\mu A$	$0.75V_{DD}$		V
			$I_{OH} = -10\mu A$	$0.9V_{DD}$		V
$V_{OH1}$	Output high voltage; port 0 in external bus mode		$I_{OH} = -800\mu A$	2.4		V
			$I_{OH} = -300\mu A$	$0.75V_{DD}$		V
			$I_{OH} = -80\mu A$	$0.9V_{DD}$		V
$I_{IL}$	Logical 0 input current, ports 1, 2, 3, except P1.6/SCL, P1.7/SDA	0 to +70°C	$V_{IN} = 0.45V$		-50	$\mu A$
		-40 to +85°C			-75	$\mu A$
		-40 to +125°C			-75	$\mu A$
$I_{TL}$	Logical 1-to-0 transition current, ports 1, 2, 3, except P1.6/SCL, P1.7/SDA	0 to +70°C	See note 7		-650	$\mu A$
		-40 to +85°C			-750	$\mu A$
		-40 to +125°C			-750	$\mu A$
$I_{L1}$	Input leakage current, port 0, $\overline{EA}$		$0.45V < V_I < V_{DD}$		$\pm 10$	$\mu A$
$I_{L2}$	Input leakage current, P1.6/SCL, P1.7/SDA		$0V < V_I < 6.0V$ $0V < V_{DD} < 6.0V$		$\pm 10$	$\mu A$
$I_{DD}$	Power supply current: Active mode @ 16MHz <sup>2, 11</sup> Active mode @ 24MHz <sup>2, 11</sup> Idle mode @ 16MHz <sup>3, 11</sup> Idle mode @ 24MHz <sup>3, 11</sup> Power down mode <sup>4, 5</sup> Power down mode <sup>4, 5</sup>		See note 1 $V_{DD}=6.0V$ $V_{DD}=5.5V$		26.5	mA
					33.8	mA
					6	mA
					7	mA
		-40 to +125°C			50 100	$\mu A$ $\mu A$
$R_{RST}$	Internal reset pull-down resistor			50	150	k $\Omega$
$C_{IO}$	Pin capacitance		Freq.=1MHz		10	pF

NOTES ON NEXT PAGE.

# CMOS single-chip 8-bit microcontrollers

# 80C652/83C652

### NOTES FOR DC ELECTRICAL CHARACTERISTICS:

1. See Figures 9 through 11 for  $I_{DD}$  test conditions.
2. The operating supply current is measured with all output pins disconnected; XTAL1 driven with  $t_r = t_f = 5\text{ns}$ ;  $V_{IL} = V_{SS} + 0.5\text{V}$ ;  $V_{IH} = V_{DD} - 0.5\text{V}$ ; XTAL2 not connected;  $\overline{EA} = \text{RST} = \text{Port } 0 = \text{P1.6} = \text{P1.7} = V_{DD}$ . See Figure 9.
3. The idle mode supply current is measured with all output pins disconnected; XTAL1 driven with  $t_r = t_f = 5\text{ns}$ ;  $V_{IL} = V_{SS} + 0.5\text{V}$ ;  $V_{IH} = V_{DD} - 0.5\text{V}$ ; XTAL2 not connected; Port 0 = P1.6 = P1.7 =  $V_{DD}$ ;  $\overline{EA} = \text{RST} = V_{SS}$ . See Figure 10.
4. The power-down current is measured with all output pins disconnected; XTAL2 not connected; Port 0 = P1.6 = P1.7 =  $V_{DD}$ ;  $\overline{EA} = \text{RST} = V_{SS}$ . See Figure 11.
5.  $2\text{V} \leq V_{PD} \leq V_{DDmax}$ .
6. The input threshold voltage of P1.6 and P1.7 (SIO1) meets the I<sup>2</sup>C specification, so an input voltage below  $0.3V_{DD}$  will be recognized as a logic 0 while an input voltage above  $0.7V_{DD}$  will be recognized as a logic 1.
7. Pins of ports 1, 2, and 3 source a transition current when they are being externally driven from 1 to 0. The transition current reaches its maximum value when  $V_{IN}$  is approximately 2V.
8. Capacitive loading on ports 0 and 2 may cause spurious noise to be superimposed on the  $V_{OL}$ s of ALE and ports 1 and 3. The noise is due to external bus capacitance discharging into the port 0 and port 2 pins when these pins make 1-to-0 transitions during bus operations. In the worst cases (capacitive loading > 100pF), the noise pulse on the ALE pin may exceed 0.8V. In such cases, it may be desirable to qualify ALE with a Schmitt Trigger, or use an address latch with a Schmitt Trigger STROBE input.
9. Under steady state (non-transient) conditions,  $I_{OL}$  must be externally limited as follows: Maximum  $I_{OL} = 10\text{mA}$  per port pin; Maximum  $I_{OL} = 26\text{mA}$  total for Port 0; Maximum  $I_{OL} = 15\text{mA}$  total for Ports 1, 2, and 3; Maximum  $I_{OL} = 71\text{mA}$  total for all output pins. If  $I_{OL}$  exceeds the test conditions,  $V_{OL}$  may exceed the related specification. Pins are not guaranteed to sink current greater than the listed test conditions.
10. Capacitive loading on ports 0 and 2 may cause the  $V_{OH}$  on ALE and  $\overline{\text{PSEN}}$  to momentarily fall below the  $0.9V_{DD}$  specification when the address bits are stabilizing.
11.  $I_{DDMAX}$  for other frequencies can be derived from Figure 1, where  $\text{FREQ}$  is the external oscillator frequency in MHz.  $I_{DDMAX}$  is given in mA.

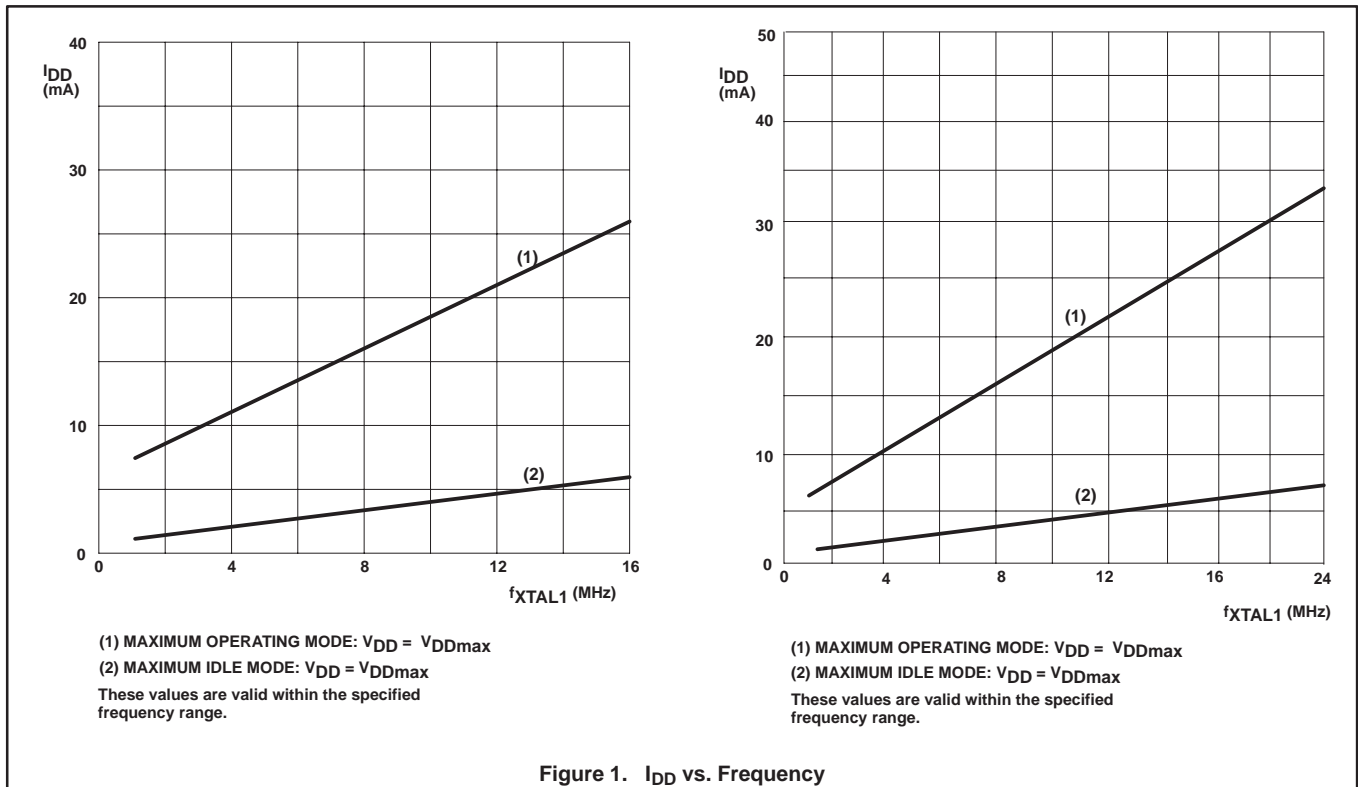

# CMOS single-chip 8-bit microcontrollers

# 80C652/83C652

## AC ELECTRICAL CHARACTERISTICS<sup>1, 2</sup> (16 MHz type)

SYMBOL	FIGURE	PARAMETER	16MHz CLOCK		VARIABLE CLOCK		UNIT
			MIN	MAX	MIN	MAX	
1/t <sub>CLCL</sub>	2	Oscillator frequency			1.2	16	MHz
t <sub>LHLL</sub>	2	ALE pulse width	85		2t <sub>CLCL</sub> -40		ns
t <sub>AVLL</sub>	2	Address valid to ALE low	8		t <sub>CLCL</sub> -55		ns
t <sub>LLAX</sub>	2	Address hold after ALE low	28		t <sub>CLCL</sub> -35		ns
t <sub>LLIV</sub>	2	ALE low to valid instruction in		150		4t <sub>CLCL</sub> -100	ns
t <sub>LLPL</sub>	2	ALE low to PSEN low	23		t <sub>CLCL</sub> -40		ns
t <sub>PLPH</sub>	2	PSEN pulse width	143		3t <sub>CLCL</sub> -45		ns
t <sub>PLIV</sub>	2	PSEN low to valid instruction in		83		3t <sub>CLCL</sub> -105	ns
t <sub>PXIX</sub>	2	Input instruction hold after PSEN	0		0		ns
t <sub>PXIZ</sub>	2	Input instruction float after PSEN		38		t <sub>CLCL</sub> -25	ns
t <sub>AVIV</sub>	2	Address to valid instruction in		208		5t <sub>CLCL</sub> -105	ns
t <sub>PLAZ</sub>	2	PSEN low to address float		10		10	ns
<b>Data Memory</b>							
t <sub>RLRH</sub>	3, 4	R <sub>D</sub> pulse width	275		6t <sub>CLCL</sub> -100		ns
t <sub>WLWH</sub>	3, 4	W <sub>R</sub> pulse width	275		6t <sub>CLCL</sub> -100		ns
t <sub>RLDV</sub>	3, 4	R <sub>D</sub> low to valid data in		148		5t <sub>CLCL</sub> -165	ns
t <sub>RHDX</sub>	3, 4	Data hold after R <sub>D</sub>	0		0		ns
t <sub>RHDZ</sub>	3, 4	Data float after R <sub>D</sub>		55		2t <sub>CLCL</sub> -70	ns
t <sub>LLDV</sub>	3, 4	ALE low to valid data in		350		8t <sub>CLCL</sub> -150	ns
t <sub>AVDV</sub>	3, 4	Address to valid data in		398		9t <sub>CLCL</sub> -165	ns
t <sub>LLWL</sub>	3, 4	ALE low to R <sub>D</sub> or W <sub>R</sub> low	138	238	3t <sub>CLCL</sub> -50	3t <sub>CLCL</sub> +50	ns
t <sub>AVWL</sub>	3, 4	Address valid to W <sub>R</sub> low or R <sub>D</sub> low	120		4t <sub>CLCL</sub> -130		ns
t <sub>QVWX</sub>	3, 4	Data valid to W <sub>R</sub> transition	3		t <sub>CLCL</sub> -60		ns
t <sub>DW</sub>	3, 4	Data setup time before W <sub>R</sub>	288		7t <sub>CLCL</sub> -150		ns
t <sub>WHQX</sub>	3, 4	Data hold after W <sub>R</sub>	13		t <sub>CLCL</sub> -50		ns
t <sub>RLAZ</sub>	3, 4	R <sub>D</sub> low to address float		0		0	ns
t <sub>WHLH</sub>	3, 4	R <sub>D</sub> or W <sub>R</sub> high to ALE high	23	103	t <sub>CLCL</sub> -40	t <sub>CLCL</sub> +40	ns
<b>Shift Register</b>							
t <sub>XLXL</sub>	5	Serial port clock cycle time <sup>3</sup>	0.75		12t <sub>CLCL</sub>		μs
t <sub>QVXH</sub>	5	Output data setup to clock rising edge <sup>3</sup>	492		10t <sub>CLCL</sub> -133		ns
t <sub>XHQX</sub>	5	Output data hold after clock rising edge <sup>3</sup>	80		2t <sub>CLCL</sub> -117		ns
t <sub>XHDX</sub>	5	Input data hold after clock rising edge <sup>3</sup>	0		0		ns
t <sub>XHDV</sub>	5	Clock rising edge to input data valid <sup>3</sup>		492		10t <sub>CLCL</sub> -133	ns
<b>External Clock</b>							
t <sub>CHCX</sub>	6	High time <sup>3</sup>	20		20	t <sub>CLCL</sub> - t <sub>CLCX</sub>	ns
t <sub>CLCX</sub>	6	Low time <sup>3</sup>	20		20	t <sub>CLCL</sub> - t <sub>CHCX</sub>	ns
t <sub>CLCH</sub>	6	Rise time <sup>3</sup>		20		20	ns
t <sub>CHCL</sub>	6	Fall time <sup>3</sup>		20		20	ns

**NOTES:**

- Parameters are valid over operating temperature range unless otherwise specified.
- Load capacitance for port 0, ALE, and PSEN = 100pF, load capacitance for all other outputs = 80pF.
- These values are characterized but not 100% production tested.

# CMOS single-chip 8-bit microcontrollers

# 80C652/83C652

## AC ELECTRICAL CHARACTERISTICS<sup>1, 2</sup> (24 MHz type)

SYMBOL	FIGURE	PARAMETER	24MHz CLOCK		VARIABLE CLOCK		UNIT
			MIN	MAX	MIN	MAX	
1/t <sub>CLCL</sub>	2	Oscillator frequency			1.2	24	MHz
t <sub>LHLL</sub>	2	ALE pulse width	43		2t <sub>CLCL</sub> -40		ns
t <sub>AVLL</sub>	2	Address valid to ALE low	17		t <sub>CLCL</sub> -25		ns
t <sub>LLAX</sub>	2	Address hold after ALE low	17		t <sub>CLCL</sub> -25		ns
t <sub>LLIV</sub>	2	ALE low to valid instruction in		102		4t <sub>CLCL</sub> -65	ns
t <sub>LLPL</sub>	2	ALE low to PSEN low	17		t <sub>CLCL</sub> -25		ns
t <sub>PLPH</sub>	2	PSEN pulse width	80		3t <sub>CLCL</sub> -45		ns
t <sub>PLIV</sub>	2	PSEN low to valid instruction in		65		3t <sub>CLCL</sub> -60	ns
t <sub>PXIX</sub>	2	Input instruction hold after PSEN	0		0		ns
t <sub>PXIZ</sub>	2	Input instruction float after PSEN		17		t <sub>CLCL</sub> -25	ns
t <sub>AVIV</sub>	2	Address to valid instruction in		128		5t <sub>CLCL</sub> -80	ns
t <sub>PLAZ</sub>	2	PSEN low to address float		10		10	ns
<b>Data Memory</b>							
t <sub>RLRH</sub>	3, 4	RD pulse width	150		6t <sub>CLCL</sub> -100		ns
t <sub>WLWH</sub>	3, 4	WR pulse width	150		6t <sub>CLCL</sub> -100		ns
t <sub>RLDV</sub>	3, 4	RD low to valid data in		118		5t <sub>CLCL</sub> -90	ns
t <sub>RHDX</sub>	3, 4	Data hold after RD	0		0		ns
t <sub>RHDZ</sub>	3, 4	Data float after RD		55		2t <sub>CLCL</sub> -28	ns
t <sub>LLDV</sub>	3, 4	ALE low to valid data in		180		8t <sub>CLCL</sub> -150	ns
t <sub>AVDV</sub>	3, 4	Address to valid data in		210		9t <sub>CLCL</sub> -165	ns
t <sub>LLWL</sub>	3, 4	ALE low to RD or WR low	75	175	3t <sub>CLCL</sub> -50	3t <sub>CLCL</sub> +50	ns
t <sub>AVWL</sub>	3, 4	Address valid to WR low or RD low	92		4t <sub>CLCL</sub> -75		ns
t <sub>QVWX</sub>	3, 4	Data valid to WR transition	12		t <sub>CLCL</sub> -30		ns
t <sub>DW</sub>	3, 4	Data setup time before WR	162		7t <sub>CLCL</sub> -130		ns
t <sub>WHQX</sub>	3, 4	Data hold after WR	17		t <sub>CLCL</sub> -25		ns
t <sub>RLAZ</sub>	3, 4	RD low to address float		0		0	ns
t <sub>WHLH</sub>	3, 4	RD or WR high to ALE high	17	67	t <sub>CLCL</sub> -25	t <sub>CLCL</sub> +25	ns
<b>Shift Register</b>							
t <sub>XLXL</sub>	5	Serial port clock cycle time <sup>3</sup>	0.5		12t <sub>CLCL</sub>		μs
t <sub>QVXH</sub>	5	Output data setup to clock rising edge <sup>3</sup>	283		10t <sub>CLCL</sub> -133		ns
t <sub>XHQX</sub>	5	Output data hold after clock rising edge <sup>3</sup>	23		2t <sub>CLCL</sub> -60		ns
t <sub>XHDX</sub>	5	Input data hold after clock rising edge <sup>3</sup>	0		0		ns
t <sub>XHDV</sub>	5	Clock rising edge to input data valid <sup>3</sup>		283		10t <sub>CLCL</sub> -133	ns
<b>External Clock</b>							
t <sub>CHCX</sub>	6	High time <sup>3</sup>	17		17	t <sub>CLCL</sub> - t <sub>CLCX</sub>	ns
t <sub>CLCX</sub>	6	Low time <sup>3</sup>	17		17	t <sub>CLCL</sub> - t <sub>CHCX</sub>	ns
t <sub>CLCH</sub>	6	Rise time <sup>3</sup>		5		5	ns
t <sub>CHCL</sub>	6	Fall time <sup>3</sup>		5		5	ns

**NOTES:**

- Parameters are valid over operating temperature range unless otherwise specified.
- Load capacitance for port 0, ALE, and PSEN = 100pF, load capacitance for all other outputs = 80pF.
- These values are characterized but not 100% production tested.

# CMOS single-chip 8-bit microcontrollers

# 80C652/83C652

## AC ELECTRICAL CHARACTERISTICS – I<sup>2</sup>C INTERFACE

SYMBOL	PARAMETER	INPUT	OUTPUT
<b>SCL TIMING CHARACTERISTICS</b>			
t <sub>HD;STA</sub>	START condition hold time	≥ 14 t <sub>CLCL</sub>	> 4.0μs <sup>1</sup>
t <sub>LOW</sub>	SCL LOW time	≥ 16 t <sub>CLCL</sub>	> 4.7μs <sup>1</sup>
t <sub>HIGH</sub>	SCL HIGH time	≥ 14 t <sub>CLCL</sub>	> 4.0μs <sup>1</sup>
t <sub>RC</sub>	SCL rise time	≤ 1μs	– <sup>2</sup>
t <sub>FC</sub>	SCL fall time	≤ 0.3μs	< 0.3μs <sup>3</sup>
<b>SDA TIMING CHARACTERISTICS</b>			
t <sub>SU;DAT1</sub>	Data set-up time	≥ 250ns	> 20 t <sub>CLCL</sub> – t <sub>RD</sub>
t <sub>SU;DAT2</sub>	SDA set-up time (before rep. START cond.)	≥ 250ns	> 1μs <sup>1</sup>
t <sub>SU;DAT3</sub>	SDA set-up time (before STOP cond.)	≥ 250ns	> 8 t <sub>CLCL</sub>
t <sub>HD;DAT</sub>	Data hold time	≥ 0ns	> 8 t <sub>CLCL</sub> – t <sub>FC</sub>
t <sub>SU;STA</sub>	Repeated START set-up time	≥ 14 t <sub>CLCL</sub>	> 4.7μs <sup>1</sup>
t <sub>SU;STO</sub>	STOP condition set-up time	≥ 14 t <sub>CLCL</sub>	> 4.0μs <sup>1</sup>
t <sub>BUF</sub>	Bus free time	≥ 14 t <sub>CLCL</sub>	> 4.7μs <sup>1</sup>
t <sub>RD</sub>	SDA rise time	≤ 1μs	– <sup>2</sup>
t <sub>FD</sub>	SDA fall time	≤ 0.3μs	< 0.3μs <sup>3</sup>

**NOTES:**

- At 100 kbit/s. At other bit rates this value is inversely proportional to the bit-rate of 100 kbit/s.
- Determined by the external bus-line capacitance and the external bus-line pull-resistor, this must be < 1μs.
- Spikes on the SDA and SCL lines with a duration of less than 3 t<sub>CLCL</sub> will be filtered out. Maximum capacitance on bus-lines SDA and SCL = 400pF.
- t<sub>CLCL</sub> = 1/f<sub>OSC</sub> = one oscillator clock period at pin XTAL1. For 63ns (42ns) < t<sub>CLCL</sub> < 285ns (16MHz (24MHz) > f<sub>OSC</sub> > 3.5MHz) the SIO1 interface meets the I<sup>2</sup>C-bus specification for bit-rates up to 100 kbit/s.

## TIMING SIO1 (I<sup>2</sup>C) INTERFACE

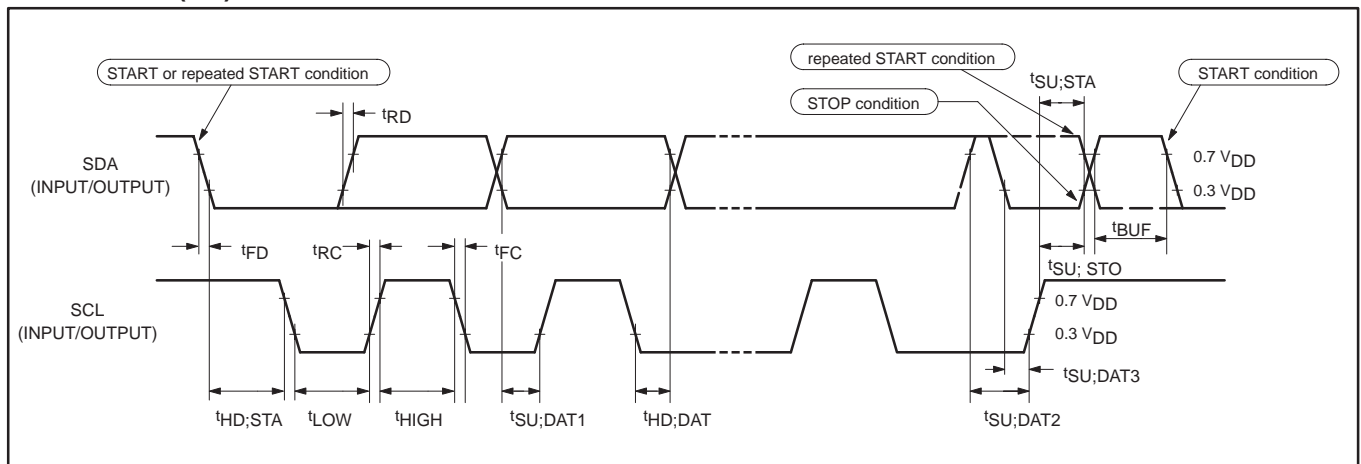

# CMOS single-chip 8-bit microcontrollers

# 80C652/83C652

## EXPLANATION OF THE AC SYMBOLS

Each timing symbol has five characters. The first character is always 't' (= time). The other characters, depending on their positions, indicate the name of a signal or the logical status of that signal. The designations are:  
 A – Address  
 C – Clock  
 D – Input data  
 H – Logic level high  
 I – Instruction (program memory contents)  
 L – Logic level low, or ALE  
 P –  $\overline{\text{PSEN}}$

Q – Output data  
 R –  $\overline{\text{RD}}$  signal  
 t – Time  
 V – Valid  
 W –  $\overline{\text{WR}}$  signal  
 X – No longer a valid logic level  
 Z – Float

**Examples:**  $t_{\text{AVLL}}$  = Time for address valid to ALE low.  
 $t_{\text{LLPL}}$  = Time for ALE low to  $\overline{\text{PSEN}}$  low.

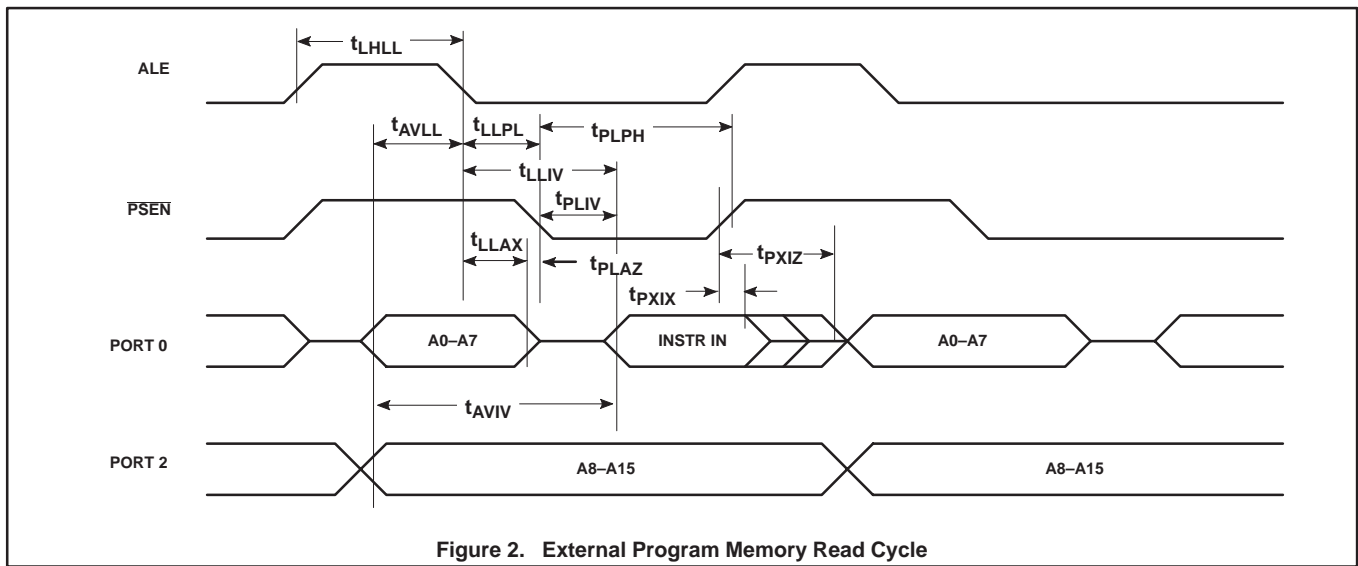

Figure 2. External Program Memory Read Cycle

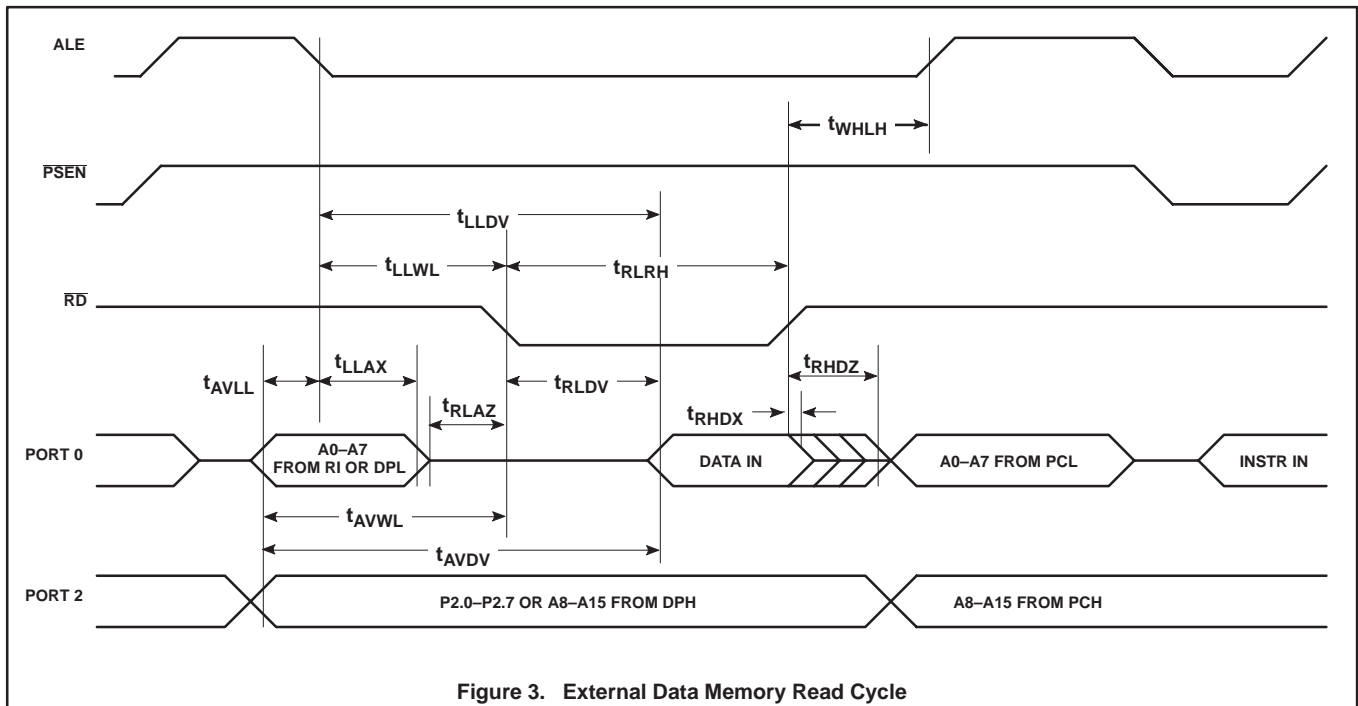
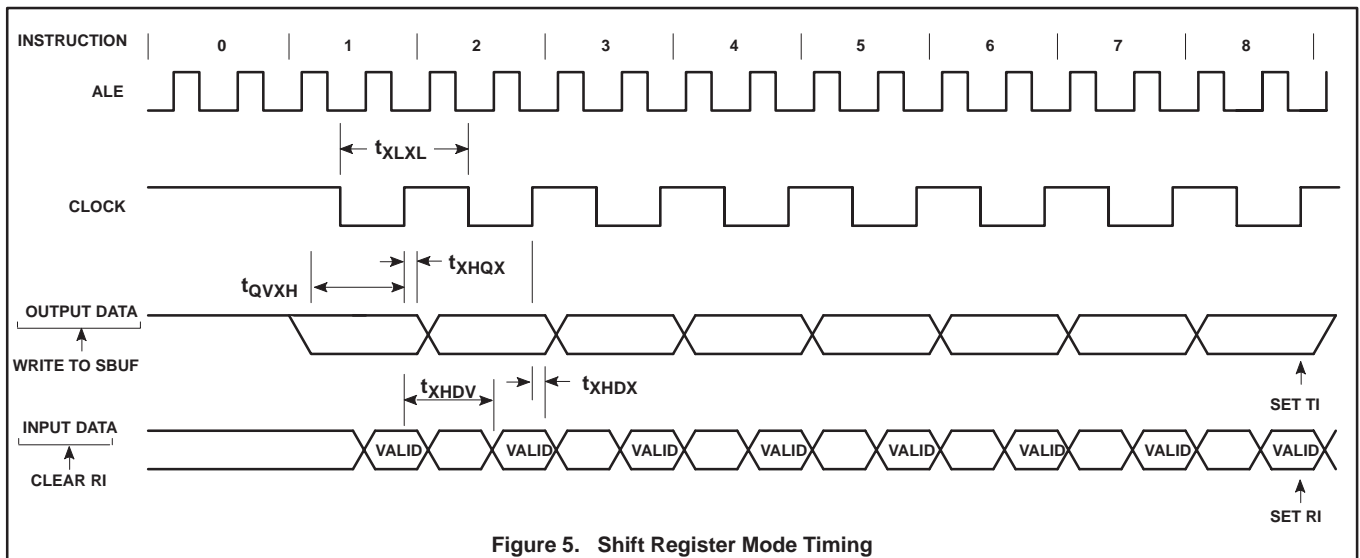
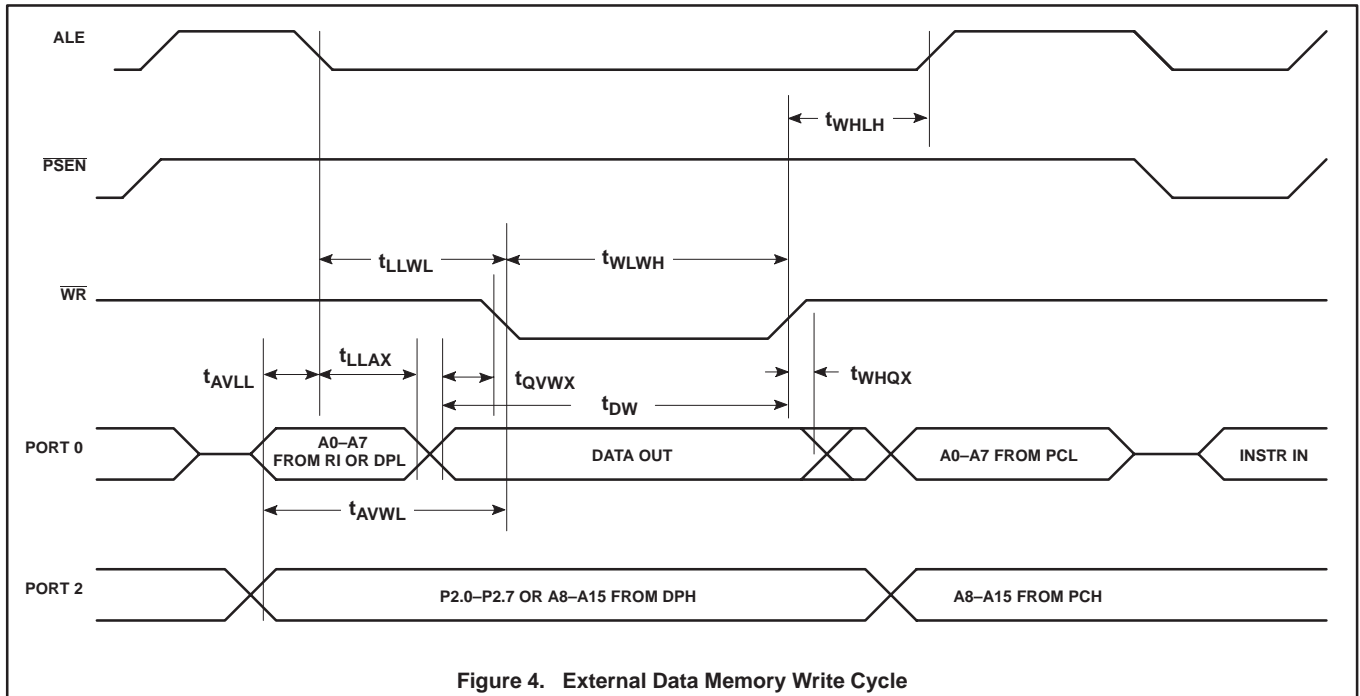

Figure 3. External Data Memory Read Cycle



CMOS single-chip 8-bit microcontrollers

80C652/83C652



CMOS single-chip 8-bit microcontrollers

80C652/83C652

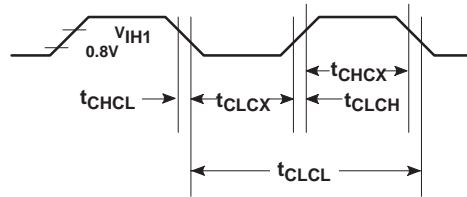
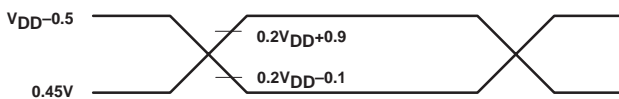
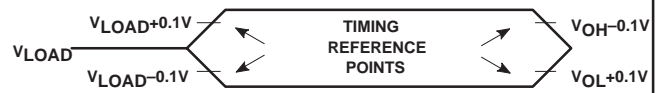

Figure 6. External Clock Drive at XTAL1



**NOTE:**  
 AC INPUTS DURING TESTING ARE DRIVEN AT  $V_{DD}-0.5$  FOR A LOGIC '1' AND 0.45V FOR A LOGIC '0'. TIMING MEASUREMENTS ARE MADE AT  $V_{IH}$  MIN FOR A LOGIC '1' AND  $V_{IL}$  MAX FOR A LOGIC '0'.

Figure 7. AC Testing Input/Output



**NOTE:**  
 FOR TIMING PURPOSES, A PORT IS NO LONGER FLOATING WHEN A 100mV CHANGE FROM LOAD VOLTAGE OCCURS, AND BEGINS TO FLOAT WHEN A 100mV CHANGE FROM THE LOADED  $V_{OH}/V_{OL}$  LEVEL OCCURS.  $I_{OH}/I_{OL} \geq \pm 20mA$ .

Figure 8. Float Waveform

CMOS single-chip 8-bit microcontrollers

80C652/83C652

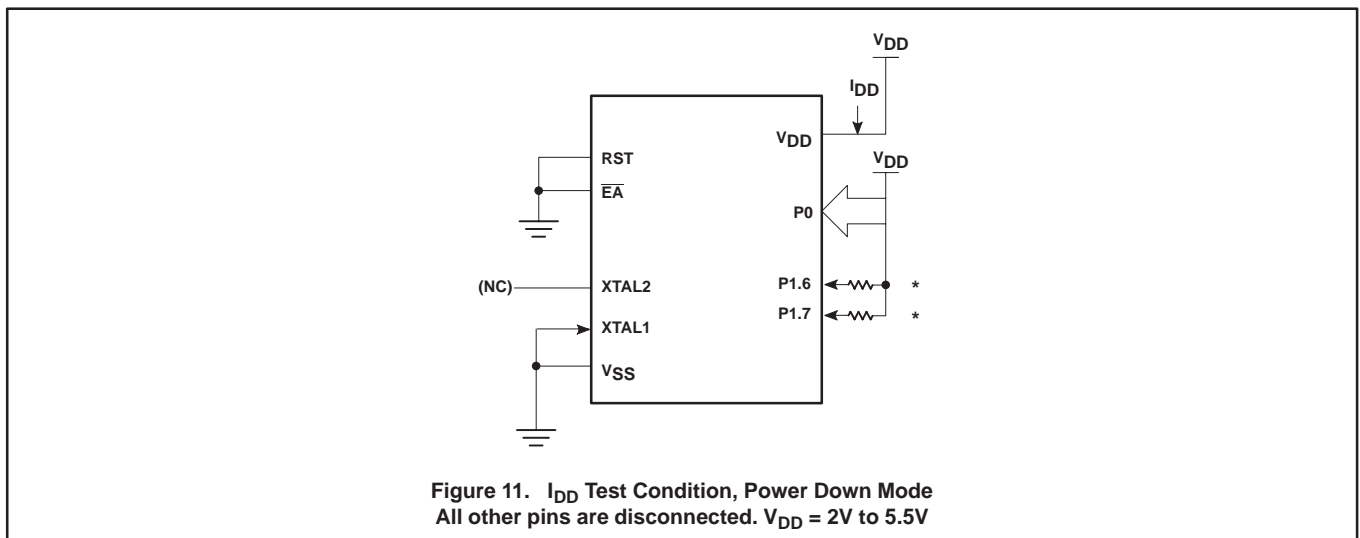
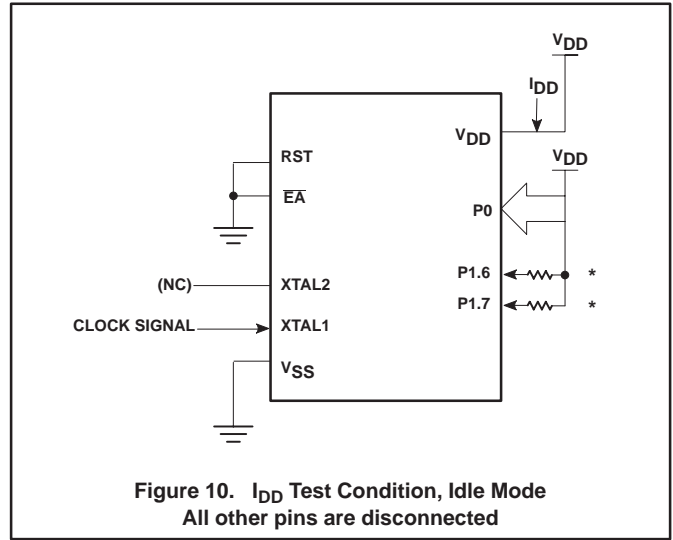
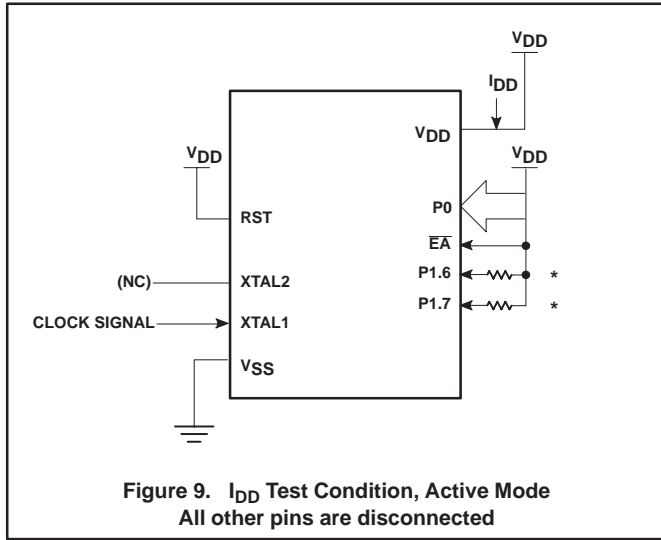

**NOTE:**

\* Ports 1.6 and 1.7 should be connected to  $V_{CC}$  through resistors of sufficiently high value such that the sink current into these pins does not exceed the  $I_{OL1}$  specification.



Purchase of Philips I<sup>2</sup>C components conveys a license under the Philips' I<sup>2</sup>C patent to use the components in the I<sup>2</sup>C system provided the system conforms to the I<sup>2</sup>C specifications defined by Philips. This specification can be ordered using the code 9398 393 40011.

CMOS single-chip 8-bit microcontrollers

80C652/83C652

DIP40: plastic dual in-line package; 40 leads (600 mil)

SOT129-1

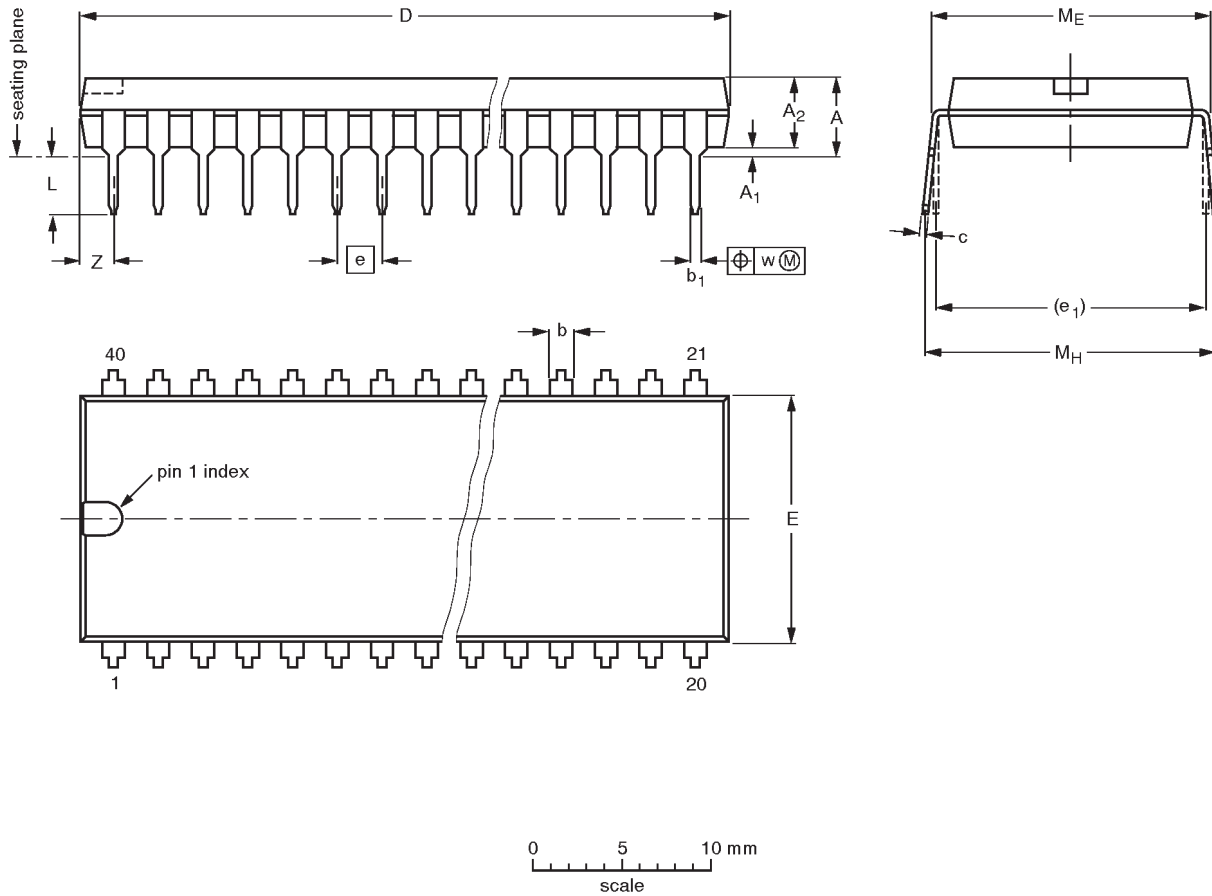

DIMENSIONS (inch dimensions are derived from the original mm dimensions)

UNIT	A max.	A <sub>1</sub> min.	A <sub>2</sub> max.	b	b <sub>1</sub>	c	D <sup>(1)</sup>	E <sup>(1)</sup>	e	e <sub>1</sub>	L	M <sub>E</sub>	M <sub>H</sub>	w	Z <sup>(1)</sup> max.
mm	4.7	0.51	4.0	1.70 1.14	0.53 0.38	0.36 0.23	52.50 51.50	14.1 13.7	2.54	15.24	3.60 3.05	15.80 15.24	17.42 15.90	0.254	2.25
inches	0.19	0.020	0.16	0.067 0.045	0.021 0.015	0.014 0.009	2.067 2.028	0.56 0.54	0.10	0.60	0.14 0.12	0.62 0.60	0.69 0.63	0.01	0.089

Note

1. Plastic or metal protrusions of 0.25 mm maximum per side are not included.

OUTLINE VERSION	REFERENCES				EUROPEAN PROJECTION	ISSUE DATE
	IEC	JEDEC	EIAJ			
SOT129-1	051G08	MO-015AJ				92-11-17 95-01-14

CMOS single-chip 8-bit microcontrollers

80C652/83C652

PLCC44: plastic leaded chip carrier; 44 leads

SOT187-2

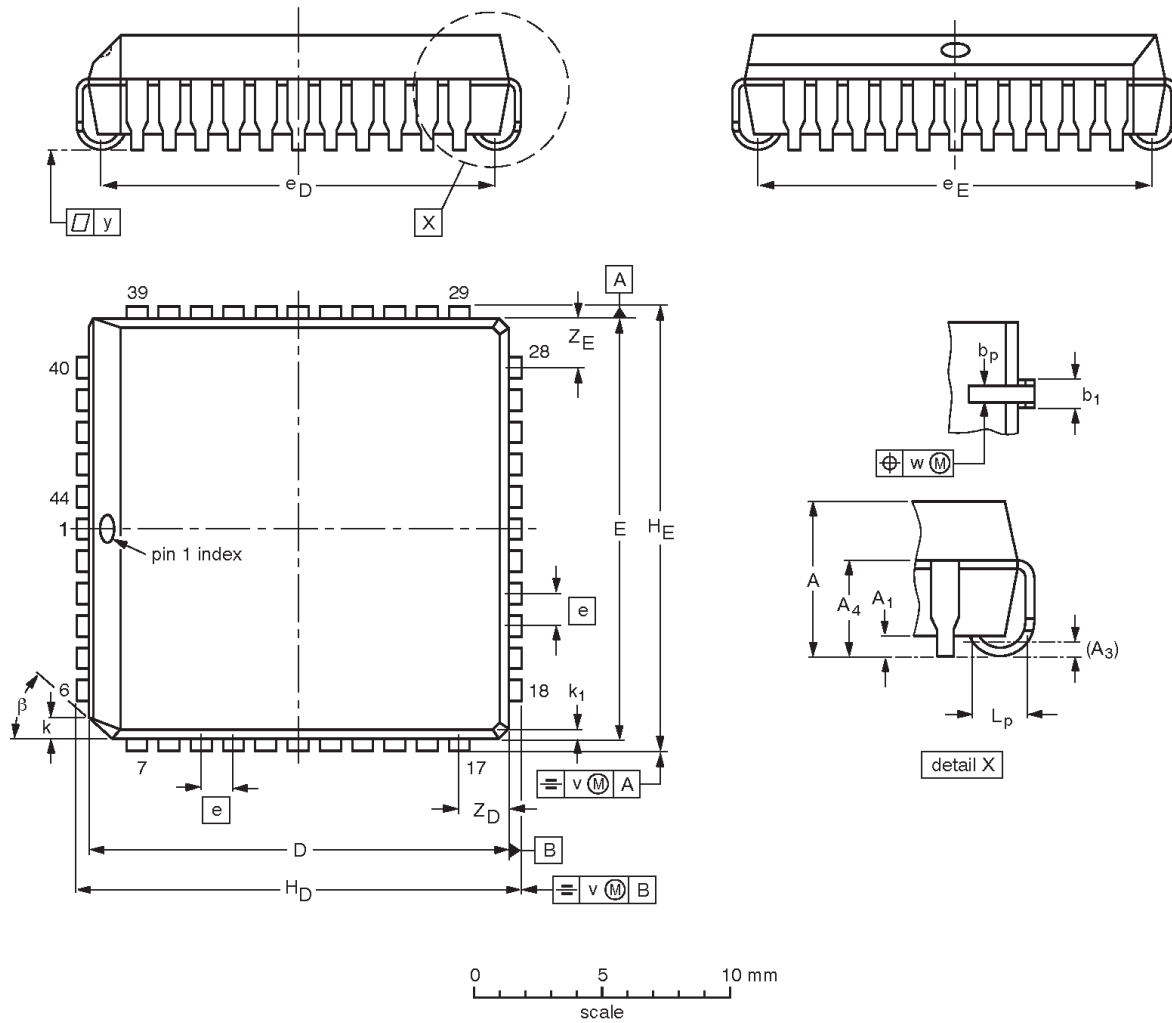

DIMENSIONS (millimetre dimensions are derived from the original inch dimensions)

UNIT	A	A <sub>1</sub> min.	A <sub>3</sub>	A <sub>4</sub> max.	b <sub>p</sub>	b <sub>1</sub>	D <sup>(1)</sup>	E <sup>(1)</sup>	e	e <sub>D</sub>	e <sub>E</sub>	H <sub>D</sub>	H <sub>E</sub>	k	k <sub>1</sub> max.	L <sub>p</sub>	v	w	y	Z <sub>D</sub> <sup>(1)</sup> max.	Z <sub>E</sub> <sup>(1)</sup> max.	β
mm	4.57 4.19	0.51	0.25	3.05	0.53 0.33	0.81 0.66	16.66 16.51	16.66 16.51	1.27	16.00 14.99	16.00 14.99	17.65 17.40	17.65 17.40	1.22 1.07	0.51	1.44 1.02	0.18	0.18	0.10	2.16	2.16	45°
inches	0.180 0.165	0.020	0.01	0.12	0.021 0.013	0.032 0.026	0.656 0.650	0.656 0.650	0.05	0.630 0.590	0.630 0.590	0.695 0.685	0.695 0.685	0.048 0.042	0.020	0.057 0.040	0.007	0.007	0.004	0.085	0.085	

Note

1. Plastic or metal protrusions of 0.01 inches maximum per side are not included.

OUTLINE VERSION	REFERENCES				EUROPEAN PROJECTION	ISSUE DATE
	IEC	JEDEC	EIAJ			
SOT187-2	112E10	MO-047AC				92-11-17 95-02-25

CMOS single-chip 8-bit microcontrollers

80C652/83C652

**QFP44: plastic quad flat package; 44 leads (lead length 1.3 mm); body 10 x 10 x 1.75 mm**

**SOT307-2**

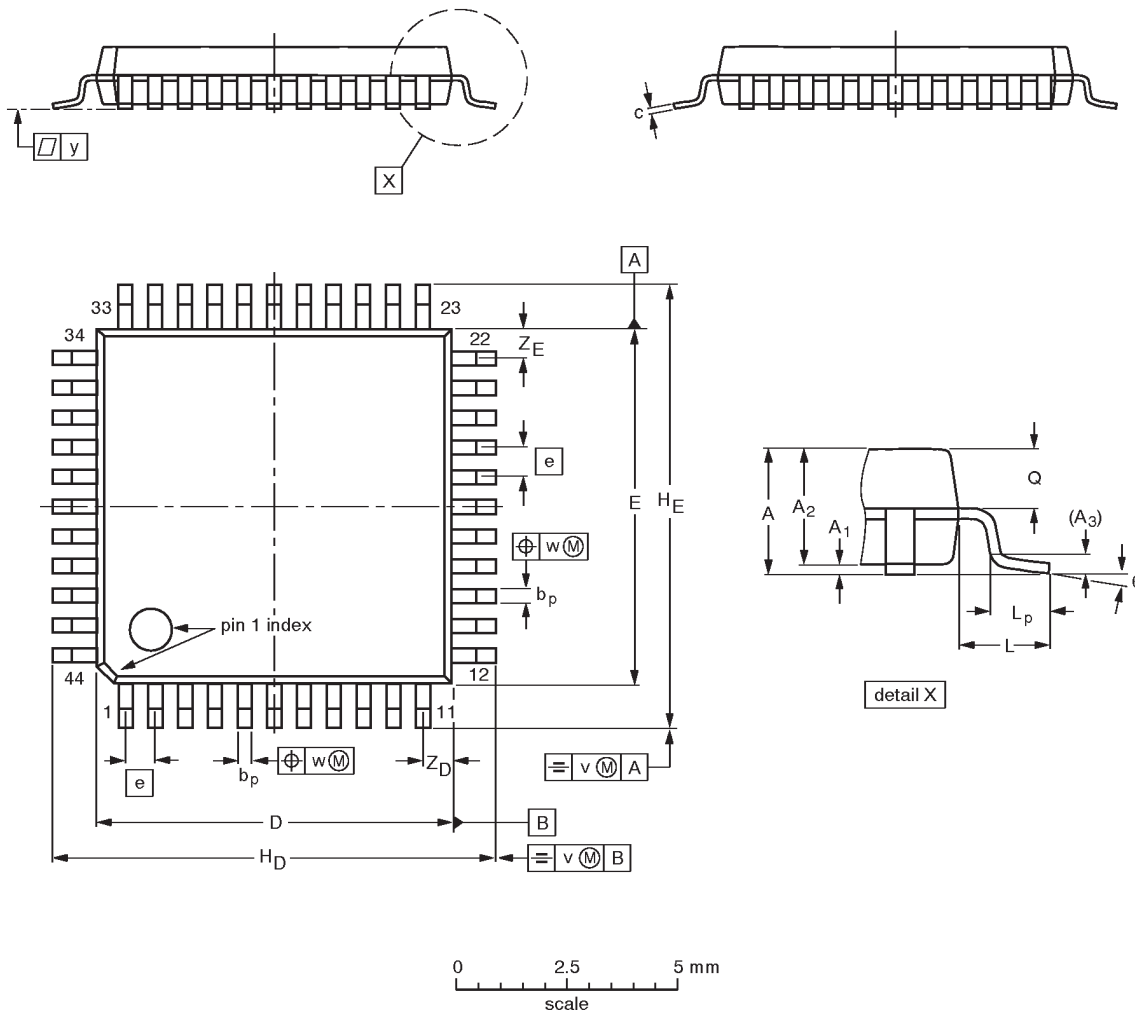

**DIMENSIONS (mm are the original dimensions)**

UNIT	A max.	A <sub>1</sub>	A <sub>2</sub>	A <sub>3</sub>	b <sub>p</sub>	c	D <sup>(1)</sup>	E <sup>(1)</sup>	e	H <sub>D</sub>	H <sub>E</sub>	L	L <sub>p</sub>	Q	v	w	y	Z <sub>D</sub> <sup>(1)</sup>	Z <sub>E</sub> <sup>(1)</sup>	θ
mm	2.10	0.25 0.05	1.85 1.65	0.25	0.40 0.20	0.25 0.14	10.1 9.9	10.1 9.9	0.8	12.9 12.3	12.9 12.3	1.3	0.95 0.55	0.85 0.75	0.15	0.15	0.1	1.2 0.8	1.2 0.8	10° 0°

**Note**

1. Plastic or metal protrusions of 0.25 mm maximum per side are not included.

OUTLINE VERSION	REFERENCES			EUROPEAN PROJECTION	ISSUE DATE
	IEC	JEDEC	EIAJ		
SOT307-2					92-11-17 95-02-04

# CMOS single-chip 8-bit microcontrollers

80C652/83C652

## 0590B 40-PIN (600 mils wide) CERAMIC DUAL IN-LINE (F) PACKAGE (WITH WINDOW (FA) PACKAGE)

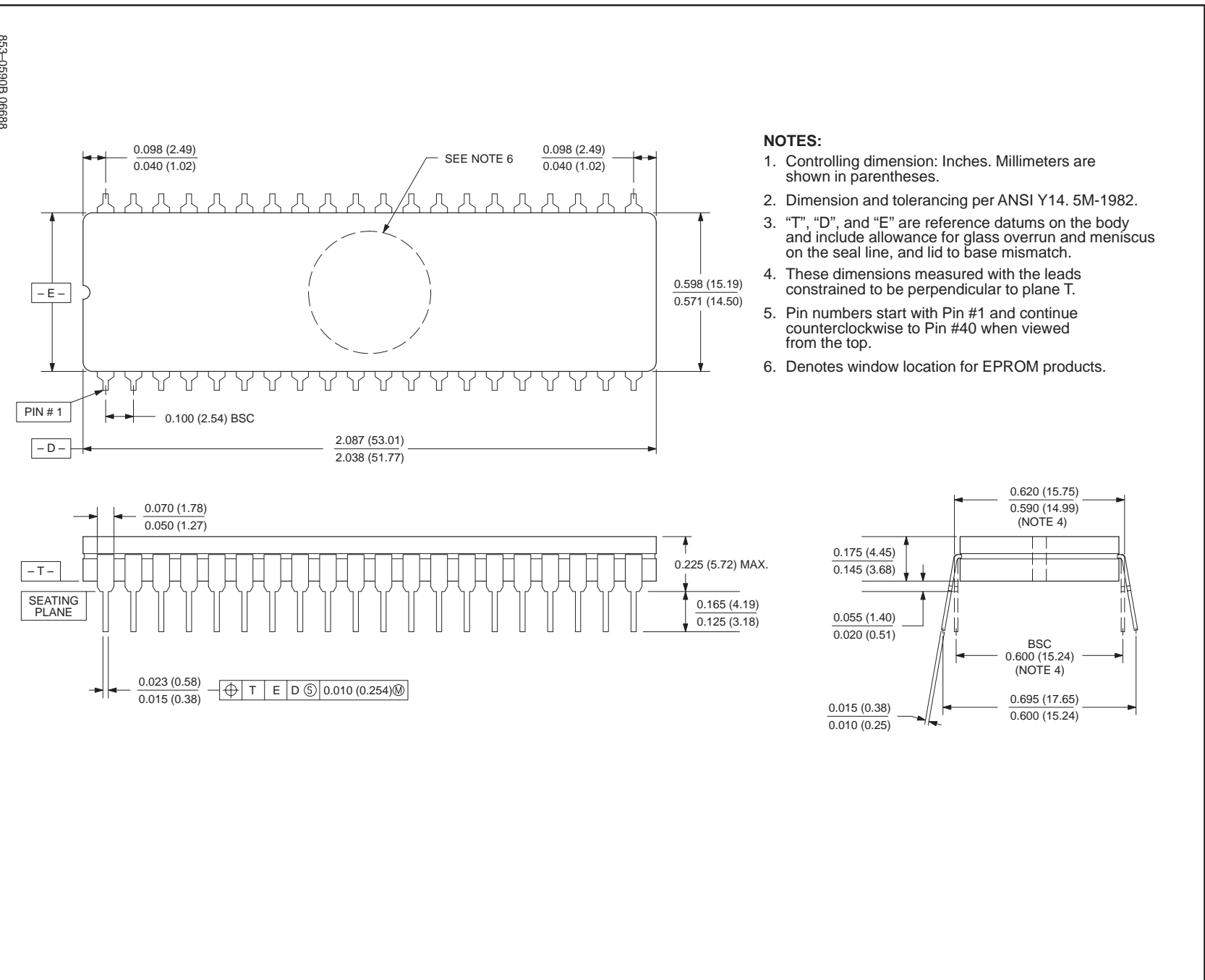

# CMOS single-chip 8-bit microcontrollers

80C652/83C652

## 1472A 44-PIN CERQUAD J-BEND (K) PACKAGE

**NOTES:**

1. All dimensions and tolerances to conform to ANSI Y14.5-1982.
2. UV window is optional.
3. Dimensions do not include glass protrusion. Glass protrusion to be 0.005 inches maximum on each side.
4. Controlling dimension millimeters.
5. All dimensions and tolerances include lead trim offset and lead plating finish.
6. Backside solder relief is optional and dimensions are for reference only.

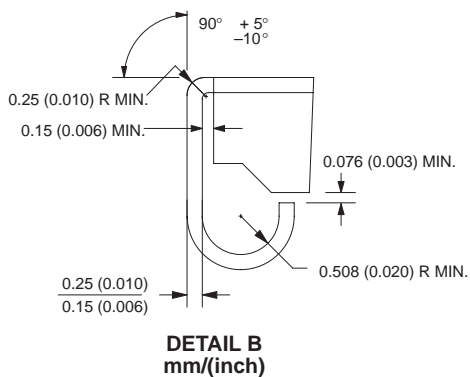
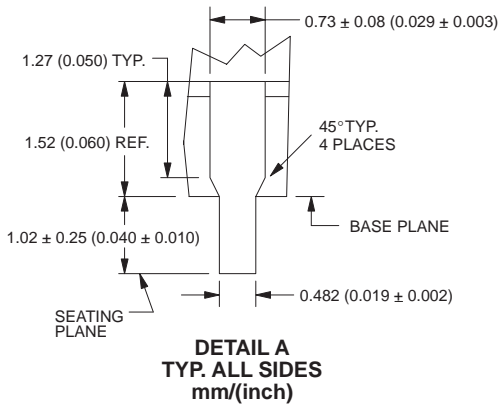
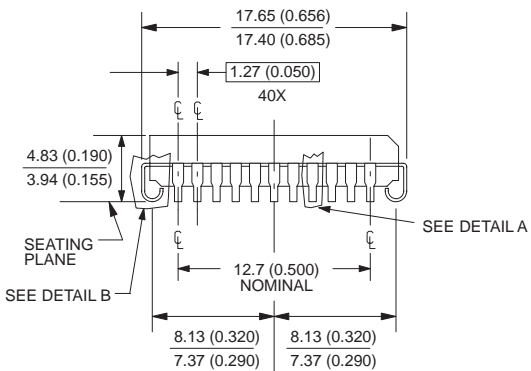
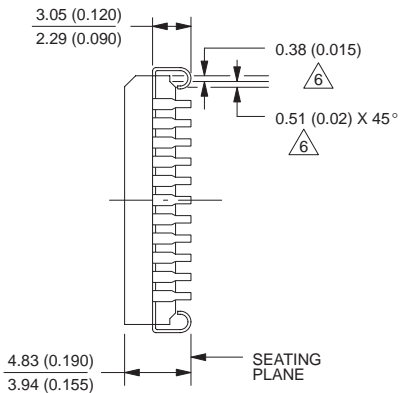
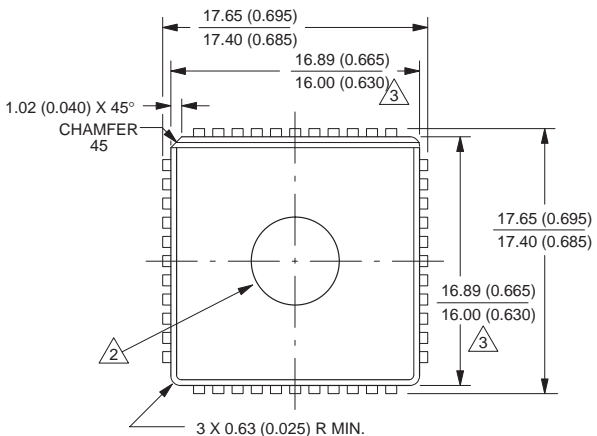

853-1472A 05854



---

CMOS single-chip 8-bit microcontrollers

80C652/83C652

---

**NOTES**

## CMOS single-chip 8-bit microcontrollers

80C652/83C652

## DEFINITIONS

Data Sheet Identification	Product Status	Definition
<i>Objective Specification</i>	<b>Formative or in Design</b>	This data sheet contains the design target or goal specifications for product development. Specifications may change in any manner without notice.
<i>Preliminary Specification</i>	<b>Preproduction Product</b>	This data sheet contains preliminary data, and supplementary data will be published at a later date. Philips Semiconductors reserves the right to make changes at any time without notice in order to improve design and supply the best possible product.
<i>Product Specification</i>	<b>Full Production</b>	This data sheet contains Final Specifications. Philips Semiconductors reserves the right to make changes at any time without notice, in order to improve design and supply the best possible product.

Philips Semiconductors and Philips Electronics North America Corporation reserve the right to make changes, without notice, in the products, including circuits, standard cells, and/or software, described or contained herein in order to improve design and/or performance. Philips Semiconductors assumes no responsibility or liability for the use of any of these products, conveys no license or title under any patent, copyright, or mask work right to these products, and makes no representations or warranties that these products are free from patent, copyright, or mask work right infringement, unless otherwise specified. Applications that are described herein for any of these products are for illustrative purposes only. Philips Semiconductors makes no representation or warranty that such applications will be suitable for the specified use without further testing or modification.

## LIFE SUPPORT APPLICATIONS

Philips Semiconductors and Philips Electronics North America Corporation Products are not designed for use in life support appliances, devices, or systems where malfunction of a Philips Semiconductors and Philips Electronics North America Corporation Product can reasonably be expected to result in a personal injury. Philips Semiconductors and Philips Electronics North America Corporation customers using or selling Philips Semiconductors and Philips Electronics North America Corporation Products for use in such applications do so at their own risk and agree to fully indemnify Philips Semiconductors and Philips Electronics North America Corporation for any damages resulting from such improper use or sale.

Philips Semiconductors  
811 East Arques Avenue  
P.O. Box 3409  
Sunnyvale, California 94088-3409  
Telephone 800-234-7381

© Copyright Philips Electronics North America Corporation 1996  
All rights reserved. Printed in U.S.A.

*Let's make things better.*